

Acoustech

OWNER'S MANUAL

Model SWA8

8" Powered Subwoofer



Speaker Systems by **B·I·C** AMERICA

NO USER SERVICEABLE PARTS ARE INSIDE.



WARNING:

TO REDUCE THE RISK OF FIRE OR ELECTRIC SHOCK, DO NOT EXPOSE THIS APPLIANCE TO RAIN OR MOISTURE

2



The lightning flash with arrowhead symbol within an equilateral triangle is intended to alert the user to the presence of uninsulated “dangerous voltage” within the product’s enclosure that may be of sufficient magnitude to constitute a risk of electric shock to persons.

Le symbole éclair avec point de flèche à l’intérieur d’un triangle équilatéral est utilisé pour alerter l’utilisateur de la présence à l’intérieur du coffret de “voltage dangereux” non isolé d’ampleur suffisante pour constituer un risque d’électrocution.



The exclamation point within an equilateral triangle is intended to alert the user to the presence of important operating and maintenance (servicing) instructions in the literature accompanying the product.

Le point d’exclamation à l’intérieur d’un triangle équilatéral est employé pour alerter les utilisateurs de la présence d’instructions importantes pour le fonctionnement et l’entretien (service) dans le livret d’instruction accompagnant l’appareil.

SAFETY INSTRUCTIONS

1. Read Instructions – Read all the safety and operation instructions before operating the SWA8.
2. Retain Instructions – Keep the safety and operating instructions for future reference.
3. Heed Warnings – Follow all warnings on the SWA8 and in these operating instructions.
4. Follow Instructions – Follow all operating and other instructions.
5. Water and Moisture – Do not use the SWA8 near water – for example, near a bathtub, washbowl, kitchen sink, laundry tub, in a wet basement or near a swimming pool.
6. Heat – Locate the SWA8 away from heat sources such as radiators, or other devices that produce heat.
7. Power Sources – Connect the SWA8 only to a power supply of the type described in these operation instructions or as marked on the SWA8.
8. Power Cord Protection – Route power supply cords so that they are not likely to be walked upon or pinched by items placed upon or against them, paying particular attention to cords at plugs, convenience receptacles, and the point where they exit the SWA8.
9. Object and Liquid Entry – Do not drop objects or spill liquids into the inside of the SWA8.
10. Damage Requiring Service – SWA8 should be serviced only by qualified service personnel when:
 - A. SWA8 power-supply cord or the plug has been damaged; or
 - B. Objects have fallen, or liquid has spilled into the SWA8; or
 - C. SWA8 has been exposed to rain; or
 - D. SWA8 does not appear to operate or exhibits a marked change in performance; or
 - E. The SWA8 has been dropped, or its chassis damaged.

11. Servicing — Do not attempt to service the SWA8 beyond those means described in this operating manual. All other servicing should be referred to the qualified service personnel.

12. To prevent electric shock, do not use the SWA8 polarized plug with an extension cord, receptacle or other outlet unless the blades can be fully inserted to prevent blade exposure.

Pour prévenir les chocs électriques ne pas utiliser cette fiche polarisée avec un prolongateur, un prise de courant ou une autre sortie de courant, sauf si les lames peuvent être insérées à fond sans laisser aucune partie à découvert.

13. Grounding or Polarization – Do not defeat the grounding or polarization of the SWA8.

14. Internal/External Voltage Selectors – Internal or external line voltage selector switches, if any, should only be reset and re-equipped with a proper plug for alternate voltage by a qualified service technician.

This apparatus does not exceed the Class A/Class B (whichever is applicable) limits for radio noise emissions from digital apparatus as set out in radio interference regulations of the Canadian Department of Communications.

ATTENTION — Le présent appareil numérique n’émet pas de bruits radioélectriques dépassant les limites applicables aux appareils numériques de class A/de class B (selon le cas) prescrites dans le règlement sur le brouillage radioélectrique édicté par les ministere des communications du Canada.

15. Altitude during operation 2000m, Maximum declared ambient 40°C.

WARNING — To reduce the risk of fire or electric shock, do not expose this component to rain or moisture.

TABLE OF CONTENTS

| | |
|---------------------------------------|----------|
| A. UNPACKING | 3 |
| B. PLACEMENT | 3 |
| C. SWA8 CONNECTIONS AND | |
| AMPLIFIER PANEL TOUR | 4 |
| D. HOOKUP | 5 |
| E. INITIAL LISTENING TESTS ... | |
| AND ADJUSTMENTS | 6 |
| F. TROUBLESHOOTING | 6 |
| G. SPECIFICATIONS | 7 |
| H. WARRANTY | 7 |

A

UNPACKING

Remove the SWA8 from its packing carefully and inspect it for any shipping damage. If you discover damage, contact your B·I·C dealer immediately.

If possible, save the carton and internal packing. It's the best possible protection for your SWA8 if you need to move it or return it for service.

Please keep your sales receipt in a secure place. It helps establish the duration of your warranty and is good for insurance purposes in case anything happens to your stereo system.

B

PLACEMENT

Where to put your SWA8

The SWA8 operates mostly at frequencies below 100Hz. These low bass frequencies are essentially omnidirectional. That means you can place the SWA8 almost anywhere in a room without compromising the effectiveness of your main stereo speakers.

Three factors need to be considered:

- 1) distance from a wall outlet;
- 2) distance from your receiver and;
- 3) proximity to walls and corners.

1. Wall outlet. Since the SWA8 requires AC power, it must be placed within six feet of wall outlet. We don't recommend extending that range with an extension cord.

2. Connections to your receiver, integrated amplifier or preamplifier. If your receiver or integrated amplifier does not have pre/main connections (see next page), hookup between the amp and SWA8 will be made with speaker wire. You can

basically place the SWA8 anywhere in a normal-sized room.

3. Proximity to walls and corners. Physical placement of the subwoofer will have a definite impact on the frequency response and the perceived amount of SWA8 bass output. Because low frequencies have long wavelengths, they are influenced by proximity to a boundary such as a wall or floor.

See Drawing 1 below. When you place the SWA8 well away from a wall, it will produce bass at a certain level. Move the SWA8 close to the wall, it will produce more output (about 3dB more). Putting the subwoofer in a corner will increase output another 3dB (6dB more than when placed away from walls and corners).

All this technical jargon may sound confusing, but it basically means that you have a number of options, each of which produces a different amount of bass. For example, if you like a lot of heavy bass, consider putting the SWA8 into a corner. If you like smoother, less-obvious bass, move the subwoofer out into the room. The main thing to remember is that there is no "right" or "wrong" place to put the SWA8 (assuming it's less than six feet from a wall receptacle). It all depends on how much bass you want.

Another reason to experiment — because low bass waves are very large (up to forty feet or more across!), they tend to cancel and reinforce each other, causing places in the room where there is lots of bass and others where there isn't very much at all. If you walk around your listening room while playing music, you'll probably discover these sorts of areas where bass is either exaggerated or reduced. Needless to say, if your main listening area ends up in a "dead" space, you will need to move the SWA8 so that bass is more normal.

Incidentally, moving the SWA8 around won't affect the stereo imaging of your main stereo system, so feel free to try various subwoofer positions.

Connecting the SWA8 to a wall plug

The SWA8 draws a moderately high amount of current. We do not recommend plugging it into a "convenience" outlet (switched or unswitched) that is often found on the back of receivers and other stereo components.

Instead, connect the SWA8 ONLY to its own AC outlet. See items 8 and 9 in the Safety Instructions at the beginning of this manual.

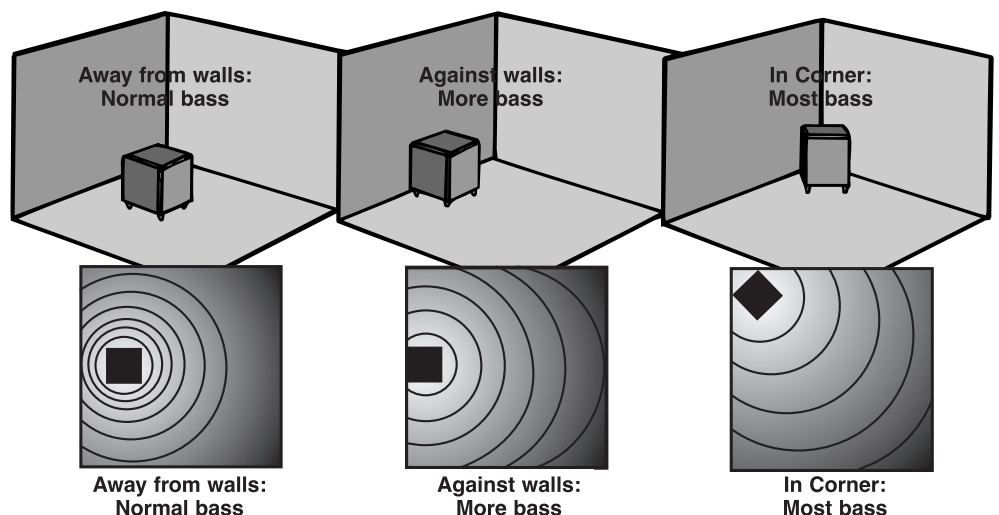

DRAWING 1 - SWA8 placement

C

Subwoofer Amplifier Tour

Before actual hookup, you should familiarize yourself with the connections on the back of the subwoofer, as shown in Figure 2 below.

1. POWER INDICATOR. When the amplifier is ON, this indicator will be green. When the amplifier is in the STANDBY mode, as mentioned next, this indicator will be red.

2. POWER/AUTO SWITCH. This switch turns the amplifier on and off. When the switch is in the ON position, the amplifier will stay on as long as the switch remains in that position. When

this switch is in the AUTO position, the amplifier will stay turned on as long as a music signal is being fed to the subwoofer amplifier. This way, you don't have to remember to reach down and turn your subwoofer on every time you listen to music. Instead, the amplifier switches itself on as soon as the music starts. If you stop playing music after approximately 15 to 20 minutes, the amplifier goes into STANDBY mode — see (1). When you begin to play music again, the amplifier will automatically turn on again.

We recommend that you turn the amplifier on LAST, after you've turned on your receiver/integrated amp/reamp, CD player, etc. Some components send

out loud, low-frequency THUMPs when they are turned on. These are not only startling and annoying, but could also cause damage to your subwoofer if the volume control is turned up high.

3. VOLUME control. Rotating this knob clockwise increases the output level of the subwoofer. To start out, make sure that the VOLUME is turned all the way down (fully counterclockwise). Later, after some initial listening tests, you can adjust the volume to your own tastes. However, care should be taken not to overdrive the subwoofer to the point of audible distortion.

4. FREQUENCY CONTROL. This control determines what lower part of the frequency spectrum will be reproduced by the SWA8 and what higher parts will be handled by your main speaker. It is a "crossover" control. Rotating the knob sets the point where all lower frequencies will be handled by the subwoofer and all higher frequencies will be routed to your main stereo speakers.

To keep from affecting the stereo imaging of your main speakers we recommend that the FREQUENCY control be set at the lower frequency setting that adds good bass and blends well with your existing speakers. Typically, somewhere between 80Hz and 100Hz is a good starting point. You will need to experiment with the setting that yields the best result for your own particular speakers and room.

5. SUB IN. Connect a digital amplifier or a receiver/integrated amplifier using a RCA cable.

6. REMOVABLE FUSE. This is the power fuse. Under normal circumstances it should not require any attention. If, however, the unit will not turn on when plugged into a known good 120 volt outlet, the fuse should be removed and checked.

4

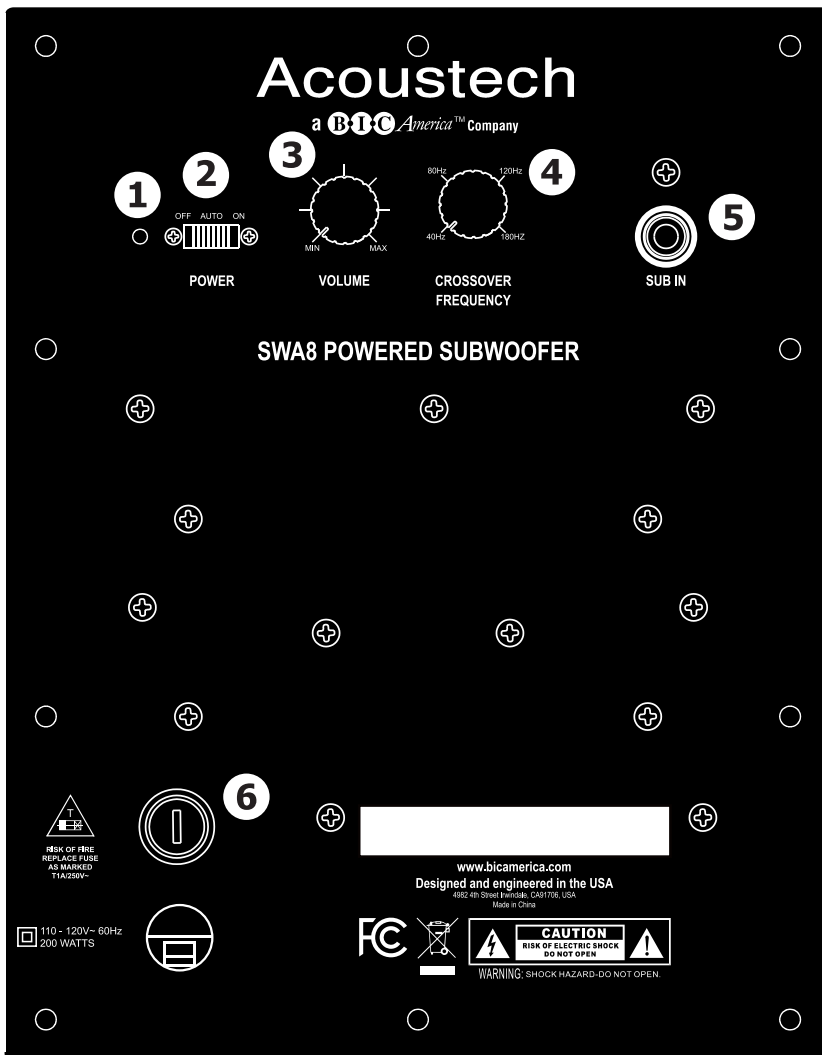

Figure 2

D

HOOKUP Speaker Wire Tips

A word about speaker wire – There are a number of quality speaker wire products available today. Most of these products offer obvious sonic benefits over lamp cord and light gauge wires. B·I·C Speaker Systems come equipped with inputs that allow the greatest flexibility and choice of hookup wire and connectors. The choice of speaker wire is dependent on the type of amplifier, the distance you intend to run the wire, and your budget, among other things. If in doubt as to which brand or type of wire and connector to use, consult your audio dealer.

Most speaker wire is polarity coded. This means that each conductor is labeled either (+) positive or (-) negative. The (+) positive side may be a different color or texture than the (-) negative side. On the back of your amplifier, each channel is probably labeled (+) and (-) as well as color coded red for (+) positive and black for (-) negative. B·I·C speaker terminals are color coded red for (+) positive and black for (-) negative. Be sure to hook (+) to (+), (red to red), and (-) to (-), (black to black).

All connections should be tight and close fitting. Inspect connections for frays and stray strands of wire touching both (+) and (-) terminals. (This will cause a short and, perhaps, damage your equipment.)

Hooking Up Your New SWA8 Subwoofer

STOP! - Make sure that you consult your amplifier's owner's manual regarding speaker hookup. Your amplifier should be turned off throughout this procedure.

Hookup

IMPORTANT: Make certain all stereo system components including the subwoofer are turned OFF before proceeding.

Line level (subwoofer) hookup

Refer to Figure 3 for proper connection. This hookup method will require a long (depending on the location of your receiver and subwoofer) male RCA to RCA line level cable to connect the subwoofer. The satellites connect to the receiver as shown.

5

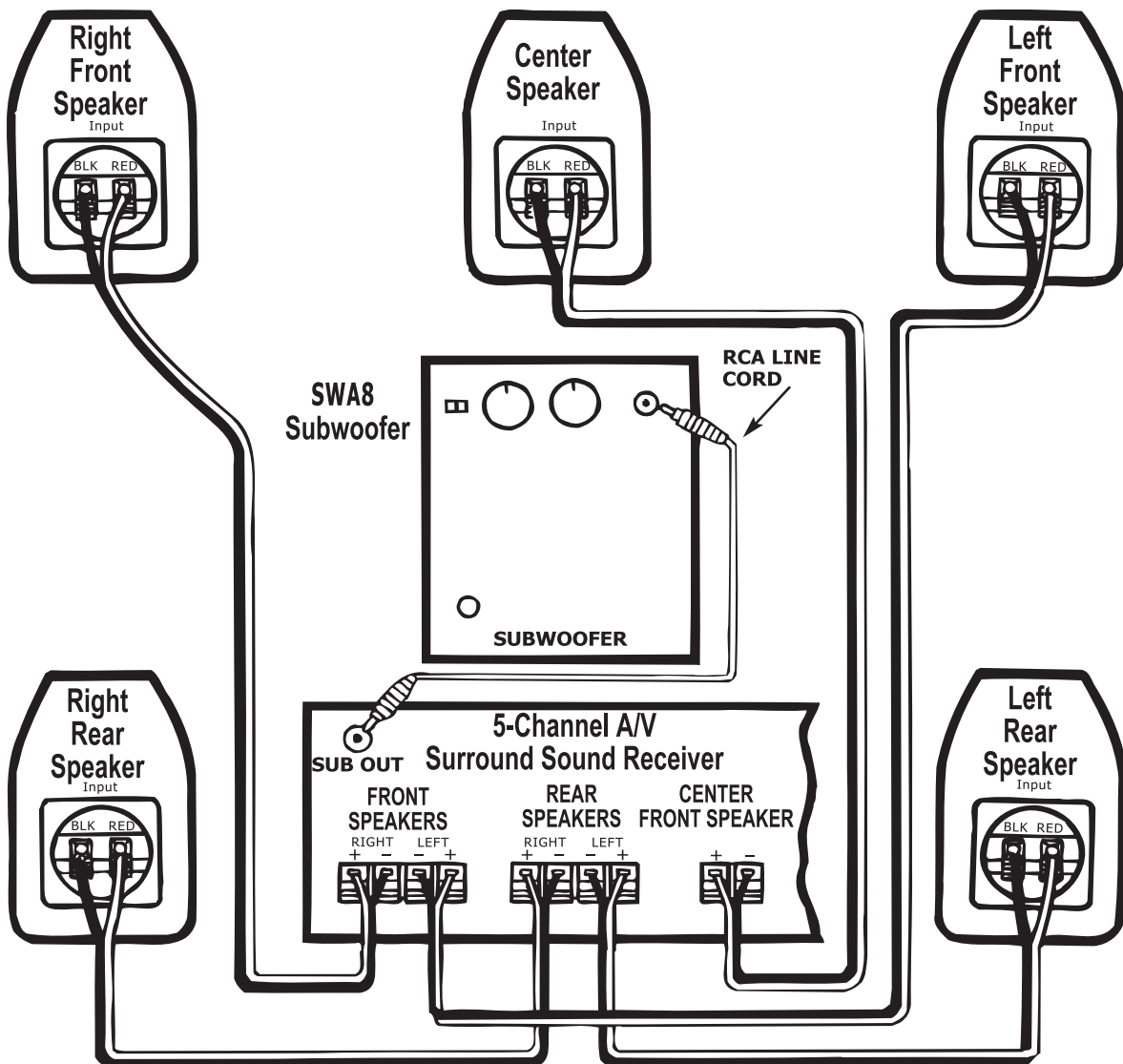

Figure 3 - Line Level Hookup

E

INITIAL LISTENING TEST

- 1. Double-check all connections.
- 2. Make sure that the volume controls on both the subwoofer and your receiver/integrated amp/preamp are turned all the way down (fully counter-clockwise). Set the frequency control to 80 Hz.
- 3. Turn on your stereo system. THEN turn on the subwoofer. Confirm that the green POWER indicator is glowing. If it isn't, check the power connections between the subwoofer and the wall socket.
- 4. Play a musical selection that you are familiar with. Pick a song that has regular low bass beats. Advance the receiver/integrated amp/preamp's volume control up to a normal listening level. If you don't hear sound through your main speakers, turn off the system and check connections.
- 5. If sound is indeed coming out of your main speakers, turn the subwoofer's VOLUME control clockwise until you hear noticeable additional bass. If you don't hear bass by the time you have advanced the subwoofer's VOLUME control halfway, turn off the system and check connections.
- 6. Adjust the subwoofer's VOLUME control until you are satisfied with the amount of bass. You may want to try several different compact discs while determining how high to adjust the subwoofer VOLUME. The amount of bass varies from disc to disc and between different types of music.
- 7. Change the FREQUENCY control to higher and lower settings. If the FREQUENCY control is set too high, you'll start to hear low midrange (voices and instruments) through it. This will negatively affect the stereo imaging of your main speakers. Back the FREQUENCY setting off until you hear only bass from the SWA8. If the FR-

EQUENCY control is set too low, you simply won't get much output from the subwoofer. Move it back closer to 80Hz.

□ 8. After you are satisfied with the output of your subwoofer, you can make all your volume settings through your main stereo system's volume control. The only time you might want to re-adjust the subwoofer's VOLUME is when you encounter a musical selection that has abnormally low – or high – bass.

You can leave the subwoofer turned on and in STANDBY mode when not in use. It does not draw much power in this state and will be ready to add low bass the moment you begin to play music. Remember, you don't have to do anything except leave the POWER switch in the AUTO position. The subwoofer will automatically go into STANDBY mode after 15 to 20 minutes, when no music is playing.

However, if you're not using your stereo system for a long period of time (such as when you're on vacation), turn the POWER switch to the OFF position FIRST, before your other components.

A Word About Power Handling

Usually if distortion is heard when the speakers are being driven at loud levels, it is caused by driving (turning up) the amplifier too loud and not driving the speakers with more power than they can handle. Remember, most amplifiers put out their full rated power well before the volume control is turned all the way up! If your speakers distort when you play them loud, turn down the amplifier or get a bigger one. B·I·C Speaker Systems are designed to the highest possible value and performance standards. Our confidence in their quality is such that B·I·C America offers customers a transferable limited warranty as explained on page 8.

Caring for Your B·I·C Speaker

The subwoofer cabinet is finished with a very high quality polymer laminate covering that is both attractive and

serves as an excellent protection for the wood cabinet. The system can be cleaned with a damp, soft cloth or you may use a high-quality furniture polish to maintain the original luster.

F

Troubleshooting

Before returning your SWA8 for service, you can save time (and often embarrassment) by checking for a few problems that are most often encountered.

Power light is not lit. No sound.

1. Is your SWA8 plugged in to a live AC wall socket?
2. Is the power switch on?
3. Has the SWA8 overheated and shut off temporarily?

No sound from either set of speakers.

1. Are your other components turned on?
2. Is the receiver or preamp set to the appropriate input and is that sound source playing?
3. Do you have an unconnected tape monitor selected?
4. Is the SWA8 correctly connected to your receiver, preamplifier or integrated amplifier?

Sound comes from main speakers but not subwoofer

1. Is the SWA8's VOLUME control turned up?
2. Check the speaker connections for small strands of wire touching both terminals.

Sound comes from the subwoofer but not your main speakers

1. confirm that the power amplifier is turned on.
2. check the RCA patch cord
3. check the speaker wire connections between the power amplifier and main or satellite speakers.

Bass is muffled or weak

1. Check speaker wire polarity of all connections.

2. Reposition your subwoofer. At some points in the room, its output may be cancelled by the geometry of the room. Moving the SWA8 can eliminate this problem.

Please refer to Item 10 in the Safety Instructions for conditions that ALWAYS require service by qualified personnel.

If you have tried all the above and still cannot get the SWA8 to operate properly, consult your dealer or call B·I·C.



SWA8 Specifications

8" long-throw woofer, auto on/off, vented

Enclosure Vinyl laminated

Dimensions 12¹/₁₆" H x 11¹/₄" W x 11⁷/₈" D

Power 200 watts Peak

Subsonic Filter 12 dB/octave below 20 Hz

Crossover 40-180 Hz (user variable)

Line Level Sensitivity 28 mv.

Frequency Response 33 Hz - 120 Hz (+/- 3db)



SWA8 Powered Subwoofer Limited Warranty

***DISCLAIMER**

THE WARRANTY STATED HEREIN IS IN LIEU OF ALL OTHER WARRANTIES, EXPRESS OR IMPLIED, INCLUDING MERCHANTABILITY AND FITNESS FOR PARTICULAR PURPOSE AND ALL OTHER LIABILITIES AND OBLIGATIONS OF B·I·C AMERICA, ALL OF WHICH ARE EXPRESSLY DISCLAIMED. B·I·C AMERICA HAS NOT MADE AND DOES NOT HEREBY MAKE ANY OTHER REPRESENTATION, WARRANTY OR COVENANT WITH RESPECT TO THE CONDITION, QUALITY, DURABILITY, DESIGN, OPERATION, CAPACITY, FITNESS FOR USE OR SUITABILITY OF THE SPEAKER SYSTEMS.

Exclusion of Certain Damages

B·I·C America's liability for any defective product is limited to repair or replacement of the product at our option. B·I·C America shall not be liable for incidental or consequential damages of any kind or character because of product defects.

Some states do not allow limitations on how long an implied warranty lasts and/or do not allow the exclusion or limitation of incidental or consequential damages, so the above limitations and exclusions may not apply.

This Warranty Does Not Cover:

Damage caused by abuse, accident, misuse, negligence, or improper operation.

Products that have been altered or modified.

Any product whose serial number has been altered, defaced, or removed.

Normal wear and maintenance.

Damages caused by shipping. (All claims for shipping damage must be made with the carrier.)

Warranty Service

Warranty service must be performed by an authorized service center, usually a B·I·C Speaker Systems dealer or its authorized agent. You may obtain a list of authorized service centers by contacting B·I·C at 877-558-4242.

All warranty repairs must be accompanied by the original bill of sales. No other document is acceptable or is required.

This warranty gives you specific legal rights, and you may also have other rights which vary from state to state.

Due to our continual efforts to improve product quality as new technology and techniques become available, B·I·C America reserves the right to revise its Speaker Systems specifications without notice.



B·I·C America

4982 4th Street,
Irwindale, CA 91706

www.bicamerica.com

For tech support call
1-877-558-4242(4BIC)

B·I·C America. All rights reserved.

